



GOES-R Series

Ground Segment (GS) to Data Collection System (DCS) Interface Requirements Document (IRD)

ATTACHMENT 5

DG133E-09-CN-0094

Version 2.0 - Modification 0003
July 1, 2009



U.S. Department of Commerce (DOC)
National Oceanic and Atmospheric Administration (NOAA)
National Environmental Satellite, Data, and Information Service (NESDIS)
National Aeronautics and Space Administration (NASA)

**GOES-R Series Ground Segment to
Data Collection System (DCS)
Interface Requirements Document**

Approved by:



Vanessa Griffin
GOES-R Ground Segment
Project Manager

9/10/08

Date



Ajay Mehta
OSDPD Deputy Director

10/2/08

Date

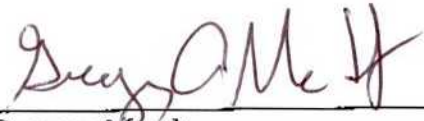

Gregory Mandt
GOES-R System
Program Director

Date

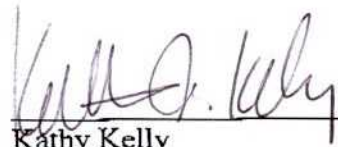

Kathy Kelly
Director,
Office of Satellite Operations

10/8/08

Date

Change Record

DOCUMENT TITLE: GOES-R GS to DCS IRD			
VERSION	DATE	PAGES AFFECTED	DESCRIPTION
1.0	21 May 08	All	Final
2.0	1 Jul 09	pp. 7, 11	Revision (CCR-01519, CCR-01520)

The document version number identifies whether the document is a working copy, final, revision, or update, defined as follows:

- **Working copy or Draft:** a document not yet finalized or ready for distribution; sometimes called a draft. Use 0.1A, 0.1B, etc. for unpublished documents.
- **Final:** the first definitive edition of the document. The final is always identified as Version 1.0.
- **Revision:** an edition with minor changes from the previous edition, defined as changes affecting fewer than one-third of the pages in the document. The version numbers for revisions 1.1 through 1.9, 2.1 through 2.9, and so forth. After nine revisions, any other changes to the document are considered an update. A revision in draft, i.e. before being re-baselined, should be numbered as 1.1A, 1.1B, etc.
- **Update:** an edition with major changes from the previous edition, defined as changes affecting more than one-third of the pages in the document. The version number for an update is always a whole number (Version 2.0, 3.0, 4.0, and so forth).

Check the VSDE at <https://vsde.nasa.gov/vsde/portal> to verify correct version prior to use.

Open Items

Section / Reference	Description

TABLE OF CONTENTS

1. INTRODUCTION	5
1.1 Purpose.....	5
1.2 Scope.....	5
1.3 Requirements Terminology	5
2. DCS AND INTERFACE DESCRIPTION	5
2.1 DCS Systems	6
2.2 GOES-R Ground Segment	7
2.3 Data Flow Description	8
3. INTERFACE REQUIREMENTS.....	10
3.1 Ground Segment Requirements	10
3.2 Data Collection System Requirements	10
4. ACRONYM LIST.....	10

LIST OF FIGURES

Figure 1. Schematic DCS Interface Context Diagram.....	8
Figure 2. Data Flow Diagram	10

1. INTRODUCTION

1.1 Purpose

The purpose of this document is to describe and specify the functional and performance interface requirements for the communication links between the GOES-R Ground Segment (GS) and the Data Collection System (DCS). This document is complementary to the GOES-R Ground Segment Functional and Performance Specification (F&PS). The GOES-R GS to DCS Interface must comply with the GOES-R Space Segment (SS) to DCS IRD.

This document is also intended to provide a basis for the subsequent development of a GOES-R GS to DCS Interface Control Document (ICD).

1.2 Scope

The interfaces addressed in this document support the exchange of data between the GOES-R GS and the DCS ground segment. Only those parameters which are necessary to specify the interface requirements will be referenced here. Specifications for the Radio Frequency (RF) links between the GOES-R Space Segment (SS) and the DCS ground segment are contained in the SS to DCS IRD. This IRD therefore:

- a) Identifies required terrestrial communications between the GS and the DCS ground segment;
- b) Establishes functional and performance requirements related to these links;
- c) Identifies supporting requirements for the GOES-R System for the DCS service.

1.3 Requirements Terminology

The statements in this document are not of equal importance. The following requirements terminology is used in this document:

- a) The term "**shall**" shall be interpreted to mean that the function, service, or capacity described is a mandatory requirement for the GS.
- b) The terms "**shall** provide the capability," "**shall** have the capability," "**shall** be capable," "**shall** enable," "**shall** permit" and "**shall** allow," shall be interpreted to mean that the function, service or capacity described is a mandatory requirement for the GS, but that the capability, service or capacity may not necessarily be exercised continuously (e.g., event driven, operator selected, operator initiated).
- c) The term "should" designates a desired level of performance the Government would like to achieve.
- d) All other declarative statements, including use of the term "will", only designate statements of fact or intentions of the Government and are not to be interpreted as contractor requirements.

Check the VSDE at <https://vsde.nasa.gov/vsde/portal> to verify correct version prior to use.

- e) The term “(TBS)” means, “to be supplied”, identifies missing or incomplete information, values, or data needed to fulfill a requirement.
- f) The term “(TBD)” means “to be determined”, identifies a missing requirement.
- g) The term “(TBR)”, means “to be refined/reviewed”, means that the requirement is subject to review for appropriateness and subject to revision.

Refer to the Statement of Work for Government and contractor responsibilities associated with TBSs, TBDs, and TBRs.

2. DCS AND INTERFACE DESCRIPTION

2.1 DCS Systems

The GOES support to the Data Collection System (DCS) is provided by GOES satellites. This system provides bidirectional link connectivity between a large number of outlying Data Collection Platforms (DCPs) and the NOAA Command and Data Acquisition Stations (CDAS) at Wallops, Virginia (WCDAS), its remote backup (RBU) site, and users' Direct Readout Ground Stations (DRGSs). These DCPs are typically small remote monitoring stations used for the collection and reporting of real-time and near real-time environmental data. . These terminals may be located anywhere in the Western hemisphere within GOES-R East or West field of view. DCPs may be located on aircraft, ships, balloons, and fixed sites and collect a wide variety of data (e.g., seismic, water level, wave state, snow and ice cover, etc.). The DCP satellite reporting modes includes random (event triggered), self-timed, and interrogate reply.

Inbound messages from the DCP to the CDAS and DRGS, containing the reported data, are called Data Collection Platform Report (DCPR) messages. These are relayed through the GOES-R satellite by a separate DCPR transponder.

Outbound link connections from the CDAS to a specific DCP, or a specific group of DCPs, for purposes of initiating a data transfer and/or re-configuring field DCP(s), are called Data Collection Platform Command (DCPC) messages. In the GOES-R satellite this shared channel is received and transponded in a dedicated DCPC transponder.

Both the DCPR and DCPC transponders are bent-pipe, i.e., receiving the uplinks within a certain frequency band, translating to a new frequency band, amplifying, and retransmitting on the downlink, but with no other processing. For the DCPR link, the uplink is Ultra High Frequency (UHF) and the downlink is L-Band; for the DCPC link, the uplink is S-Band and the downlink is UHF. In each case, the satellite antenna must provide Earth coverage out to a ground station of elevation angle of 5° or greater.

Prior to GOES-R, the DCS ground system consists of four major functional components:

1. The DCS Pilot Subsystem – Generates a pilot tone for transmission through the GOES DCPR transponder to provide the receive ground systems with a calibrated reference

signal. The CDA Stations also use the pilot in the receive IF conversion process to phase lock the DCPR downlink to a Station frequency reference.

2. The DCS Command Subsystem - Generates a satellite specific IF signal, modulated with DCP address information and commands, that is then up converted to S band by the GOES transmitter for uplink through the antenna to the GOES. This transmission provides a forward link to interrogate compatible DCPs in the field.
3. The DCS Test Transmitters – These transmitters, one for the East and one for the West, generate UHF uplinks to provide quality monitoring of the CDAS receive systems. The transmitters emulate field DCPs and transmit through the GOES DCPR transponder periodically reporting reception quality to the DAPS.
4. The DCS Automated Processing System (DAPS) – Provides for the CDAS receive data ingest, processing, archiving and dissemination of DCP message traffic. Also provides for the management functions of the DCS in supporting the system and user information database.

2.2 GOES-R Ground Segment

The next generation Geostationary Operational Environmental Satellites, designated the GOES-R Series, are required to provide continuity and improvement of remotely sensed environmental data from a geosynchronous orbit, launching no earlier than 2015 with an expected operational lifetime of 15 years. GOES-R satellites will nominally operate at two orbital locations: GOES-East at 75° W. longitude and GOES-West at 137° W. longitude (which represents a departure from the 135° W. longitude location of the current GOES-West satellite). Both satellites will fly payloads that provide a set of Unique Payload Services, including transponders that will relay data for Emergency Managers Weather Information Network (EMWIN), High Rate Information Transmission (HRIT), and Data Collection System (DCS) (*CCR01519*, *CCR01520*).

The GOES-R Ground Segment will be a distributed system of systems at three operational sites. Current operational facilities include the NOAA Satellite Operations Facility (NSOF) in Suitland, MD and the Wallops Control and Data Acquisition Station (WCDAS) at Wallops, VA. A new GOES-R, geographically diverse Remote Backup (RBU) facility will be located at Fairmont, WV (TBR). Ground Segment functions will be distributed across the prime sites. The NSOF will house primary Mission Management and Enterprise Management functions, Level 2 and higher (L2+) Product Generation, and prime Product Distribution functions. The WCDAS will provide primary space communications services and primary product generation through Level 1b (L1b). The RBU will function as an independent backup to maintain satellite health and safety and to provide the production and delivery of, at a minimum, key performance and legacy products.

Figure 1 shows a context diagram for the DCS interface.

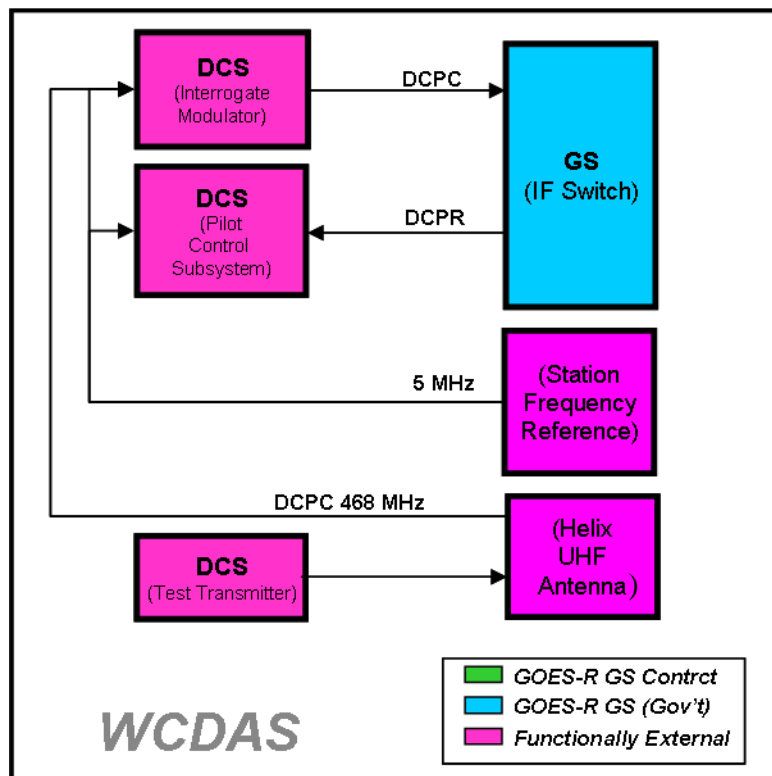

Figure 1. Schematic DCS Interface Context Diagram

2.3 Data Flow Description

DCPC. An interrogate platform command is issued every half second to each satellite. Some of these result from a database entry, some result from a missing response from a self-timed DCP and some result from a manual request by a primary user. The interrogation requests are routed to either the GOES East or GOES West DCS Command Modulator. The Command Modulator generates the modulated IF signal that is then up converted to S band by the GOES transmitter for uplink through the antenna to the GOES. The command control subsystem receives and frequency compensates the nominal 468 MHz downlink to remove the frequency uncertainty in the GOES command transponder. The resulting UHF signal can then be received by all compatible DCPs in the footprint of the spacecraft. Only the platform with the appropriate address will respond to the interrogate request.

DCPR. DCP Reports (DCPR) contain environmental sensor data that is uplinked to either the GOES East or West spacecraft. Each DCP will be assigned to one of 532 channels at 750 Hz increments from 401.701000 MHz to 402.099250 MHz to operate at 300 bps data rate. Additionally, a capability will exist to combine 3 channels for a limited number of 2250 Hz Bandwidth channels to operate at 1200 bps uplink data rate. The following types of DCPs are used in the GOES DCS:

- Self Timed, (S), that transmit data at specified times and intervals on a daily basis,

- Random Reporting, (R), that transmits data based upon an environmental threshold trigger that is detected as exceeded. These events occur at random and as such no regular time of reporting is established.
- Interrogate, (I), that transmits data in response to receiving a command from the DAPS
- Dual (D), a name assigned to DCPs that operate on international channels because the channel assignment is maintained on both satellites.

These signals are received at UHF and frequency translated in the S-band GOES transponder. The resulting signals are downlinked to the Wallops CDA station. The signals are then received by the respective GOES East or West Antenna system. The signal is amplified and down converted to a nominal 74.5 MHz. DCS Intermediate Frequency (IF). The IF signal is further down-converted to a nominal 5 MHz by the DCS Pilot Control Equipment which removes the satellite transponder frequency drift, and then routes the data through a multicoupler to the Data Acquisition and Monitoring Subsystem (DAMS) - data demodulators.

Test Transmitter (TT). The DAPS schedules test messages on every active DCS channel every two hours. This message simulates a DCP signal. The test transmitter is frequency agile and generates the message based upon a DAPS command. After issuing the command the DAPS then looks for the respective message and does a byte by byte compare with the message sent. If an error is detected an alarm is generated on the operator's console. To uplink the message the test transmitter uses either the GOES East or West helix antennas.

Pilot Signal. To compensate for frequency drift in the spacecraft DCS transponder and to adjust the overall system gain a 401.085 MHz UHF pilot signal that is referenced to the Wallops timing system is transmitted to both the GOES East and West spacecraft via a Omni directional antenna. The spacecraft processes this signal like a regular platform signal and the resulting S-band signal is detected and processed at each of the GOES receive antennas. The Pilot Control Subsystem detects this IF signal and uses its phase lock loop to adjust the downlink signal to 5 MHz. This frequency corrected 5MHz is then applied to the multicouplers and on to all Data Acquisition and Monitoring Subsystem (DAMS) chassis.

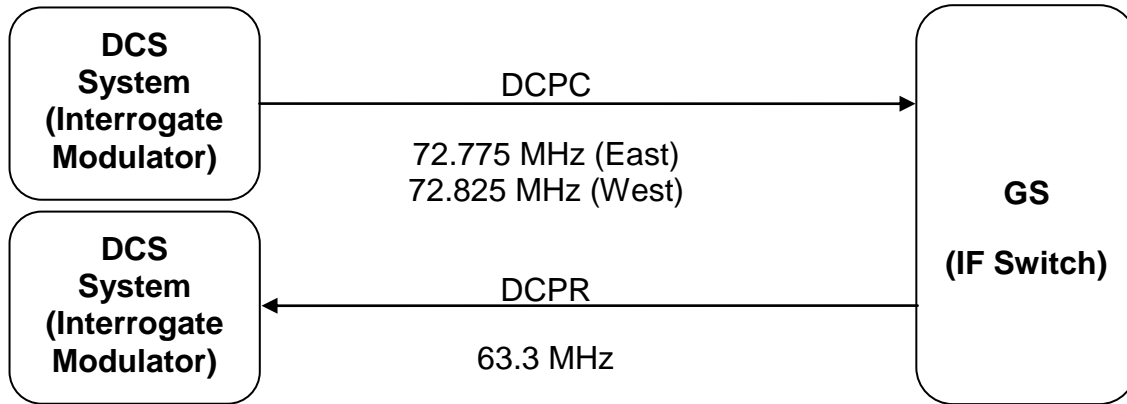

Figure 2. Data Flow Diagram

3. INTERFACE REQUIREMENTS

3.1 Ground Segment Requirements

DCS-IRD-001: The GS (IF switch) at the WCDAS **shall** receive the DCPC IF signals from the DCS System (Command Modulators).

DCS-IRD-002: The GS (IF switch) at the WCDAS **shall** send the DCPR IF signal to the DCS System (Pilot Control Subsystem).

3.2 Data Collection System Requirements

DCS-IRD-016: The DCS **shall** ensure that the mandated security mechanisms and safeguards are in place prior to the transmission and/or processing of all data between the DCS and the GOES-R GS in accordance with the federal and departmental regulations prescribed in the GOES-R GS Applicable and Reference Document List.

DCS-IRD-021: The DCS System (Command Modulator) **shall** send the DCPC IF signal to the GS (IF switch) at the WCDAS.

DCS-IRD-022: The DCS System (Pilot Control Subsystem) **shall** receive the DCPR IF signal from the GS (IF switch) at the WCDAS.

4. ACRONYM LIST

DAPS	DCS Automated Processing System
DICE	DCS Interrogate and Control Equipment
DCP	Data Collection Platform
DCPC	Data Collection Platform Command
DCPR	Data Collection Platform Report
DCS	Data Collection System

Check the VSDE at <https://vsde.nasa.gov/vsde/portal> to verify correct version prior to use.

DOC	Department of Commerce
DRGS	Direct Readout Ground Stations
EMWIN	Emergency Managers Weather Information Network
FDMA	Frequency Division Multiple Access
GOES	Geostationary Operational Environmental Satellite
GS	Ground Segment
HRIT	High Rate Information Transmission
ICD	Interface Control Document
IF	Intermediate Frequency
IRD	Interface Requirements Document
L1b	Level 1b (Calibrated, Geolocated data products)
L2+	Level 2 and higher products
NESDIS	National Environmental Satellite, Data, and Information Service
NOAA	National Oceanic and Atmospheric Administration
RBU	Remote Backup
RF	Radio Frequency
SS	Space Segment
TT	Test Transmitter
UHF	Ultra High Frequency
WCDAS	Wallops Command and Data Acquisition Station